

Fourth Edition

**Staywell**  
Part of the PetSafe family



# 600 Series - Aluminium

## Pet Doors - Small, Medium, Large & Extra Large

# Cutting Template

For fitting the pet door please refer to the user's guide.

For safety reasons it is not recommended to fit this product to glass.

Wood, PVC/uPVC/Metal and Brick **LARGE** 277mm (10<sup>7</sup>/<sub>8</sub>"

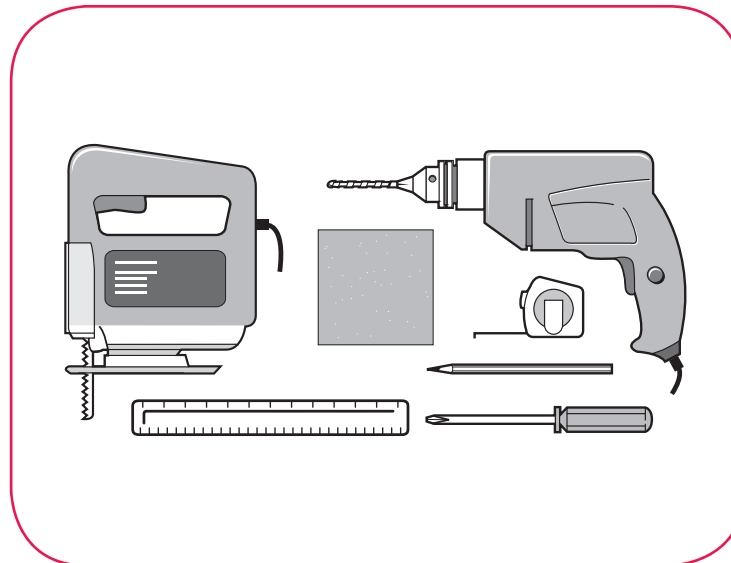

Wood, PVC/uPVC/Metal and Brick **MEDIUM** 225mm (8<sup>7</sup>/<sub>8</sub>"

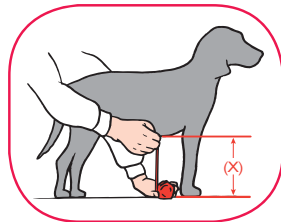

Measure pet belly height. Mark height on your door (X)

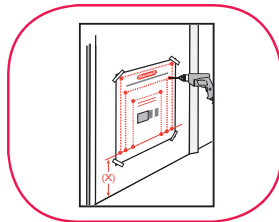

Position the template base at belly height marked on door (X). Drill holes at appropriate corners as indicated.

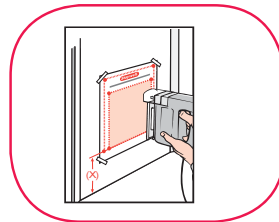

Using a jig or key-hole saw cut along the appropriate cutting line as indicated.

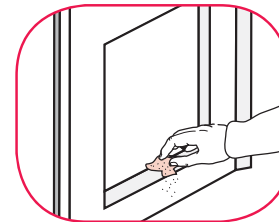

Smooth out any rough edges with sand paper. Refer to user's guide for fitting.

Wood, PVC/uPVC/Metal and Brick **SMALL** 150mm (5<sup>7</sup>/<sub>8</sub>"



Fits wooden doors

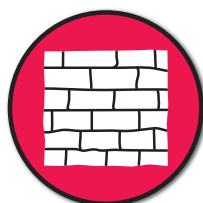

Fits brick walls

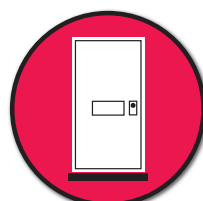

Fits PVC/uPVC/Metal

Wood, PVC/uPVC/Metal and Brick **EXTRA LARGE** 642mm (25<sup>1</sup>/<sub>4</sub>"

Wood, PVC/uPVC/Metal and Brick **LARGE** 451mm (17<sup>3</sup>/<sub>4</sub>"

Wood, PVC/uPVC/Metal and Brick **MEDIUM** 348mm (13<sup>3</sup>/<sub>4</sub>"

Wood, PVC/uPVC/Metal and Brick **SMALL** 245mm (9<sup>5</sup>/<sub>8</sub>"

**FR Instructions de découpage**

Pour des raisons de sécurité, il n'est pas recommandé de monter ce produit sur une surface en verre.

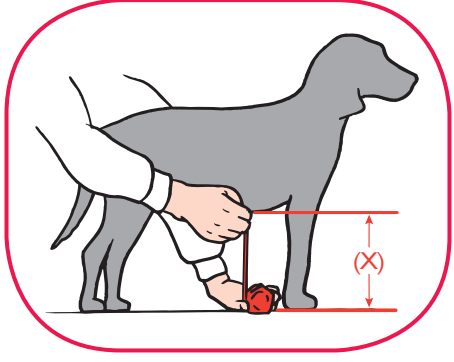

Mesurez la hauteur au niveau du ventre. Tracez une marque indiquant la hauteur sur votre porte (X).

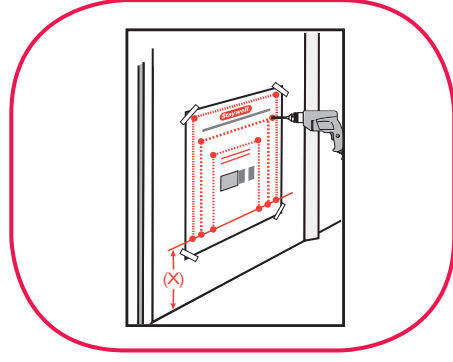

Positionnez la base du modèle au niveau de la marque de hauteur du ventre indiquée sur la porte (X). Percez des trous dans les coins tel qu'indiqué.

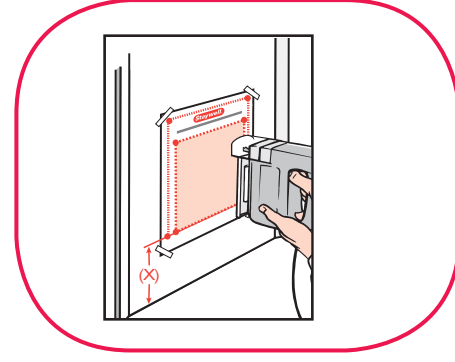

À l'aide d'une scie sauteuse ou d'une scie à guichet, découpez le long de la ligne de découpage tel qu'indiqué.

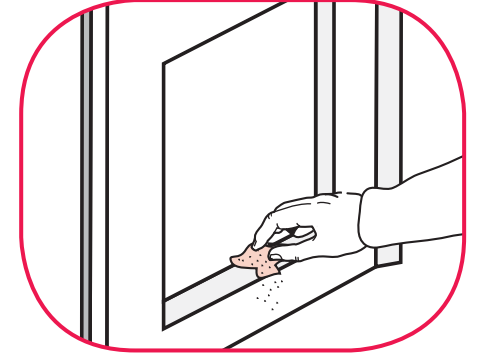

Faites disparaître les bords rugueux à l'aide de papier abrasif. Consultez le guide de l'utilisateur pour l'assemblage.

**NL Boorinstructies voor deurmontage**

Om veiligheidsredenen raden wij u af om dit product in het glas te monteren.

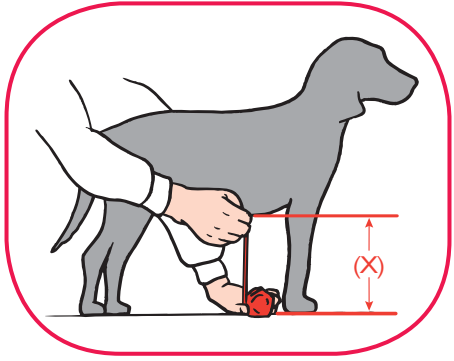

Meet de buikhoogte van uw huisdier. Markeer deze hoogte op uw deur (X).

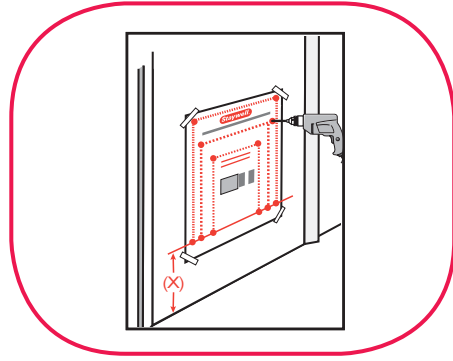

Leg het sjabloon op de plek waar u de buikhoogte heeft gemarkeerd (X). Boor een gat in alle vier hoeken, zoals afgebeeld.

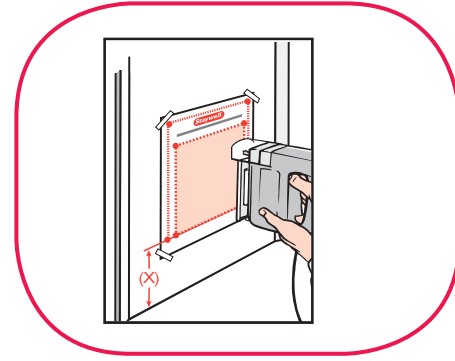

Snij met een decoupeerzaag of een sleutelgatzaag het gat uit langs de lijnen van het uitsnijcirkel, zoals afgebeeld.

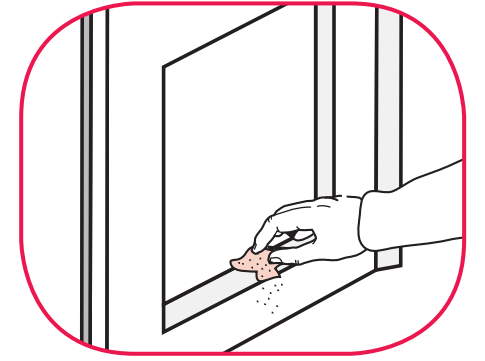

Maak alle ruwe kanten glad met het stukje schuurpapier. Volg de instructies voor montage uitgelegd in de gebruiksaanwijzing.

**DE Schneideanleitung**

Aus Sicherheitsgründen wird davon abgeraten, dieses Produkt in Glastüren einzubauen.

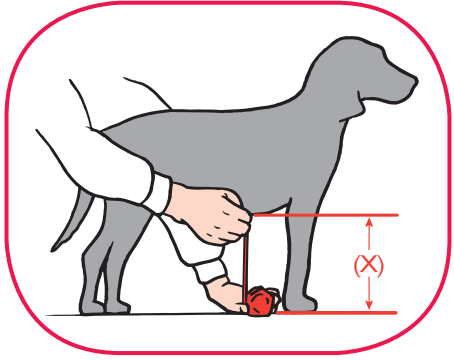

Messen Sie die Bauchhöhe Ihres Haustieres. Markieren Sie diese Höhe an Ihrer Tür mit einem (X).

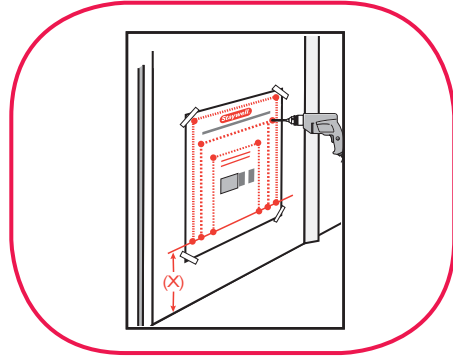

Richten Sie die untere Linie der Vorlage mit der markierten Bauchhöhe an der Tür aus (X). An den Ecken wie angezeigt Löcher bohren.

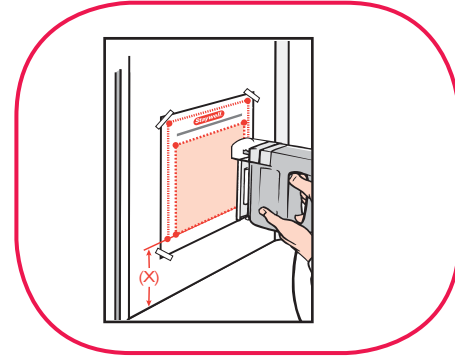

Mit einer Bogen- oder Stichsäge wie angezeigt entlang der Schnittlinie schneiden.

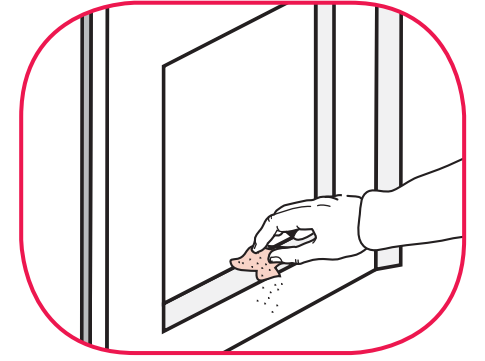

Raustellen mit Schleifpapier glatt schleifen. Einbauanleitung im Benutzerhandbuch.

**IT Istruzioni per il taglio**

Per ragioni di sicurezza non si raccomanda di montare questo prodotto su vetro.

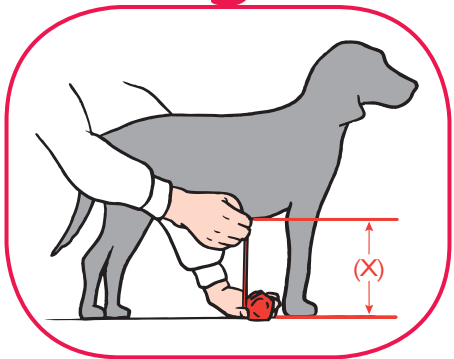

Misurare l'altezza del vostro animale in corrispondenza della pancia. Segnare l'altezza sulla porta (X).

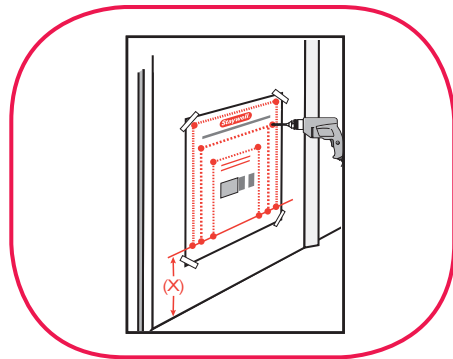

Collocare la base della sagoma all'altezza pancia segnata sulla porta (X). Praticare sugli angoli appropriati un foro con il trapano come illustrato.

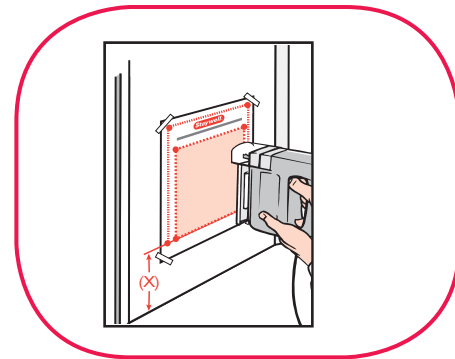

Usando un seghetto da traforo o gattuccio tagliare lungo la linea di taglio appropriata come illustrato.

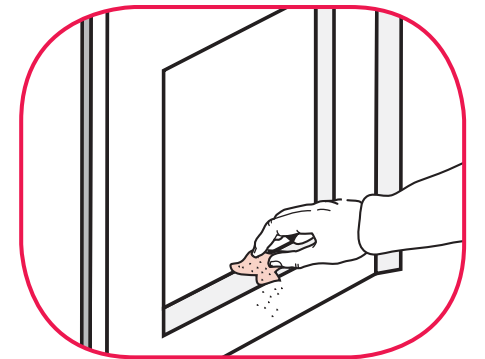

Levigare i bordi con carta vetrata. Consultare le istruzioni per l'uso per il montaggio.

**ES Guía para cortar el agujero**

Por razones de seguridad, no se recomienda instalar este producto en vidrio.

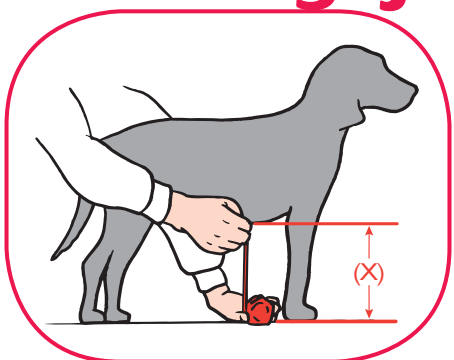

Mida la altura del suelo a la panza de su mascota. Marque con un lapicero esta medida en la puerta. (X)

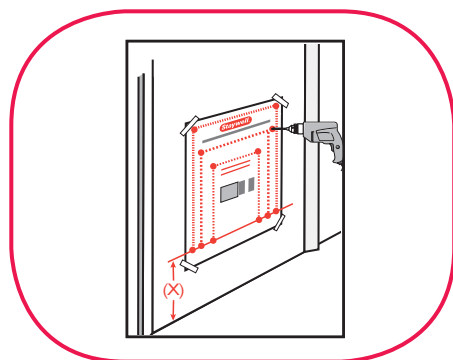

Coloque la base de la plantilla en la puerta dónde marcó la altura de la panza. (X) Taladre los agujeros para tornillos en las esquinas, tal como se indica.

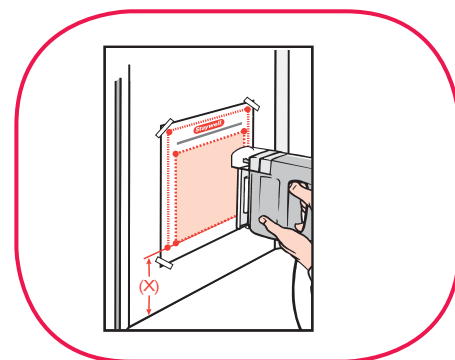

Con una sierra de vaivén o de pelo, corte por la línea de puntos, tal como se indica en la plantilla.

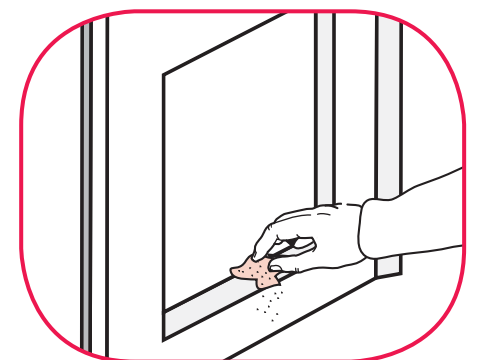

Use papel de lija para quitar las asperezas. Para instalar la puerta de mascota, consulte la guía del usuario.